

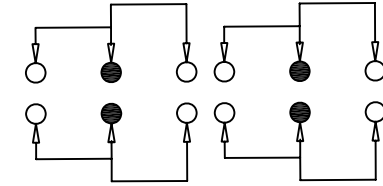

CAD FILE:

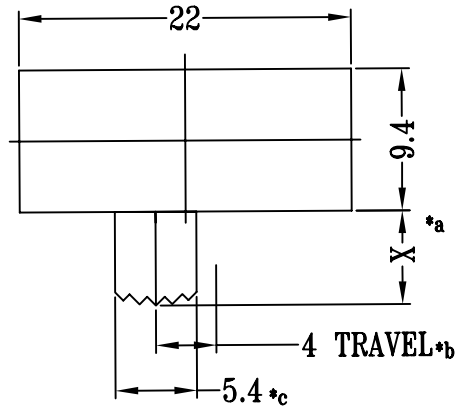

SCHMATIC (NON-SHORTING)

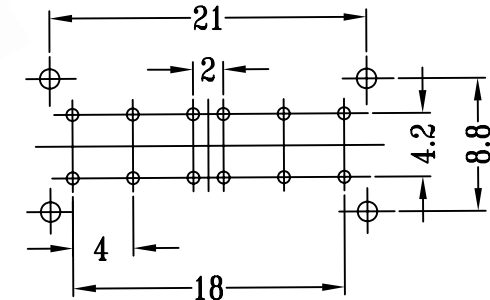
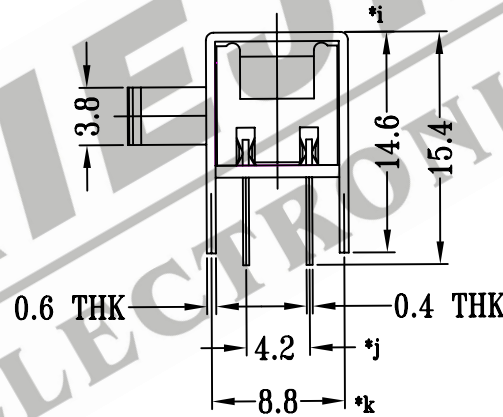
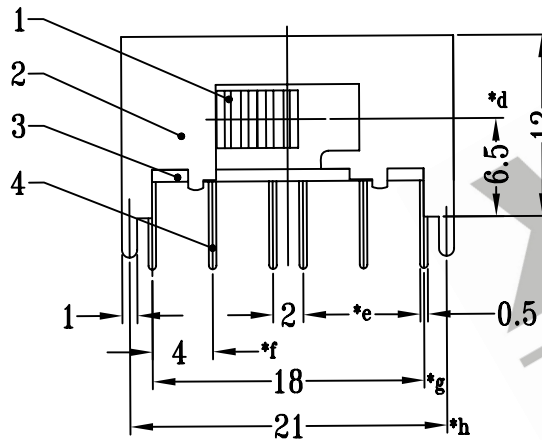

PCB LAYOUT

注: *表示关键尺寸 (11个)

				TOLERANCE		SHENZHEN XIEJIA ELECTRONICS CO.,LTD.				
				UNLESS SPECIFIED						
				WITHIN: 1.5±0.1mm		ISSUE	DATE	DESCRIPTIONS		
				OVER : 1.5±0.2mm				APPD.		
8						TITLE : HORIZONTAL SLIDE SWITCH		UNIT : MM	DRWG NO.: XJ-DR-SK42H13-00	
7	STEEL BALL	STEEL	1	NATURAL	MODEL: SK-42H13		SCALE: 2:1	DWN.	ZHOUYU	2005-12-1
6	SPRING	STEEL WIRE	1	TEMPER	ALL MATERIALS MUST BE COMPLIANT TO ROHS			CHK'D	FANGYING	2005-12-1
5	CONTACT CLIP	PBS STRIP	4	Ag PLATED				APPD.	KANGXINAN	2005-12-1
4	TERMINAL	BRASS STRIP	12	Ag PLATED OVER Ni PLATED						
3	BASE	PHENOLIC RESIN	1	NATURAL						
2	FRAME	STEEL STRIP	1	Ni PLATED						
1	KNOB	POM	1	BLACK						
NO.	PART NAME	MATERIAL	Q'TY	FINISHING						